

空心轴滑环系列

产品系列介绍

华盛电气的空心轴导电滑环采用先进的簇刷式技术，接触件使用耐磨耐腐蚀三级超硬金表面处理技术，硬度、强度、耐磨性及导电率均优于连接器接触件国际军工标准规范，环道表面十分光滑，表面粗糙度 $\leq Ra0.4$ ，每路信号进行匹配设计，杜绝传输信号在高速旋转出现掉包现象。

中心通孔从0到1000mm可选，电流从0到5000A可选，电压最高可达10000V，能全面满足您的不同传动方案。



电气特性		机械特性		环境特性	
通道数	06/12/18/24	工作转速	0 ~ 300RPM	工作温度	-40°C ~ +80°C
工作电流	5A(信号)/10A	触点材料	贵金属		
工作电压	440VAC / DC	壳体材料	铝合金 / 工程塑料	工作湿度	$\leq 70\%$ RH
耐压强度	两者之间 500VAC@50Hz	导线规格	铁氟龙或其它导线	防护等级	IP50
绝缘电阻	$\geq 500M\Omega@500VDC$	导线长度	转子/定子:300mm	其它性能	
动态电阻 波动值	最小可达1m Ω	力 矩	$\leq 0.1N.m/6路$ $+0.03N.m/6路$	使用寿命	1000万转（可定制）

可定制选项说明：

- 1、工作温度：标准品-30°C~+70°C，定制温度范围：-60°C~+200°C
- 2、工作转速：标准品0~300RPM，0~20000RPM（可定制）
- 3、参考使用寿命：标准品1000万转@300RPM，超长寿命滑环可定制
- 4、壳体：工程塑料、铝合金、不锈钢
- 5、防护等级：IP50-IP68（可定制）
- 6、导线末端接插件及长度。
- 7、可与气、液、射频、光纤旋转关节集成组合滑环
- 8、可多种信号（如工业以太网、串口、工业总线、USB、SDI等）、电流同时混合传输

空心轴滑环系列

产品特点

- 可传输模拟和数字信号
- 功率与信号混合传输，信号类别如下：
 - (1)、以太网：速率（10Mbps/100Mbps/1000Mbps）
 - (2)、工业以太网：EtherNet, EtherCAT, ProfiNet, Powerlink, SercosIII/IP等
 - (3)、高清视频：SDI, LVDS等
 - (4)、串口通信：RS232, RS485, RS422等
 - (5)、通用串行总线：USB2.0
 - (6)、工业现场总线：CANBus, ProfiBus, InterBus, CC-Link, DeviceNet等
 - (7)、传感器信号：热电阻, 热电偶, 应变片等
- 超长寿命，免维护
- 安装便捷

典型应用

工业自动化设备、医疗设备、风力发电设备、测试设备、展览/显示设备、机器人设备、转台设备、游艺设备、动中通、高铁设备、包装机械、船舶海工设备、工程机械等。

安装说明及示意图

- 1、滑环体不得作承重用，导线也不得承受外部拉扯力；
- 2、安装滑环时，转子和定子不能都采用硬连接，建议用4个紧定螺钉将滑环转子固定在旋转轴上，拨杆插入定子端止转片，同时梳理好导线，避免导线出现干涉或破损；
- 3、滑环属于精密电气元件，如果使用环境恶劣，应增加防护措施，或者选用防护等级更高的定制滑环。

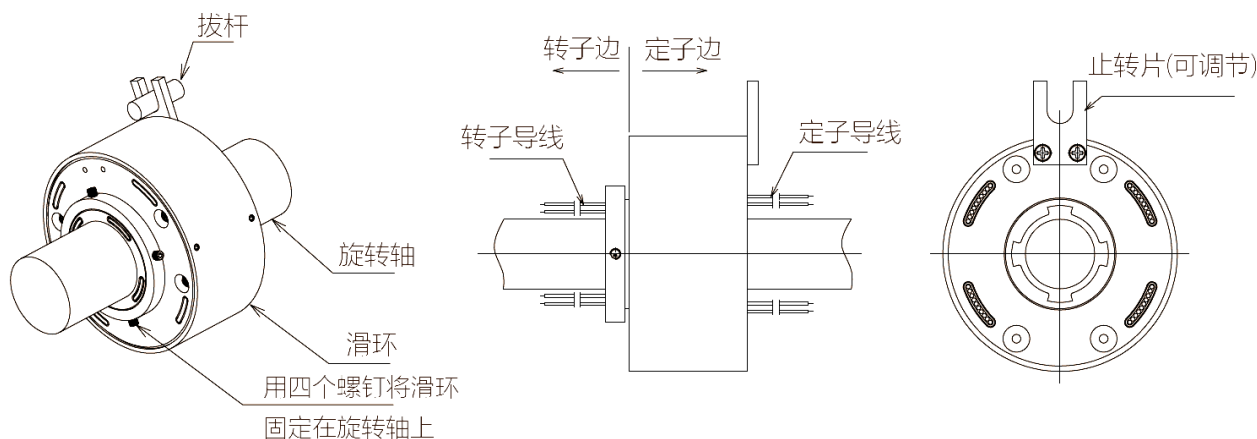

空心轴滑环系列

订购型号说明

例：HT2578-P0610-S08-C

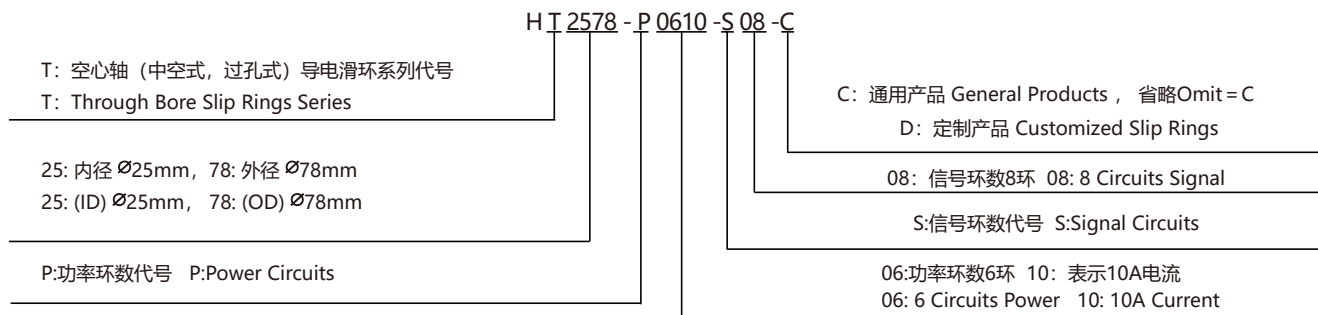

各环路导线色码表 Color Code Of Lead Wire

环道 Ring #	1	2	3	4	5	6	7	8	9	10	11	12
颜色 Color	黑 Black	褐 Brown	红 Red	橙 Orange	黄 Yellow	绿 Green	蓝 Blue	紫 Violet	灰 Grey	白 White	粉红 Pink	浅蓝 Azury

备注: 当出线数量超过12种颜色, 则用重复的颜色, 并用号码管做出区分。

Remark: If more than 12wires, repeat as sequence, use number tubes to distinguish them.

标准系列选型表

HT系列过孔式导电滑环 HT Series Through Bore Slip Rings

型号 Part NO.	内径(mm) ID(mm)	外径(mm) OD(mm)	线路数(mm) NO.Of Circuits(mm)
HT1256	12.7	56	1~36
HT1256F	12.7	56	1~36
HT2578	25.4	78	1~36
HT2578F	25.4	86	1~36
HT3899	38.1	99	1~36
HT3899F	38.1	99	1~36
HT50119	50	119	1~36
HT50119F	50	119	1~36

空心轴滑环系列

HT1256系列选型表

HT1256系列 HT1256 Series				
型号 Part NO.	线路数 NO.of Circuits			长度L(mm) Length (mm)
	10A	5A	信号Signal	
HT1256-P0605	0	6	0	41.7
HT1256-P1205	0	12	0	67.5
HT1256-P1805	0	18	0	67.5
HT1256-P2405	0	24	0	92.7
HT1256-P3005	0	30	0	105.6
HT1256-P3605	0	36	0	118.5
HT1256-P0610	6	0	0	41.7
HT1256-P1210	12	0	0	67.5
HT1256-P1810	18	0	0	80.1
HT1256-P2410	24	0	0	105.6
HT1256-S09	0	0	9	42.3
HT1256-S18	0	0	18	67.5
HT1256-S27	0	0	27	92.7
HT1256-S36	0	0	36	105.6
HT1256-P0605-S09	0	6	9	67.5
HT1256-P0605-S18	0	6	18	80.1
HT1256-P1205-S09	0	12	9	80.1
HT1256-P1205-S18	0	12	18	92.7
HT1256-P1805-S09	0	18	9	92.7
HT1256-P1805-S18	0	18	18	118.5
HT1256-P0610-S09	6	0	9	67.5
HT1256-P0610-S18	6	0	18	92.7
HT1256-P1210-S09	12	0	9	80.7
HT1256-P1210-S18	12	0	18	105.6

空心轴滑环系列

HT1256F系列选型表

HT1256F系列 HT1256F Series				
型号 Part NO.	线路数 NO.of Circuits			长度L(mm) Length (mm)
	10A	5A	信号Signal	
HT1256F-P0605	0	6	0	41.7
HT1256F-P1205	0	12	0	67.5
HT1256F-P1805	0	18	0	67.5
HT1256F-P2405	0	24	0	92.7
HT1256F-P3005	0	30	0	105.6
HT1256F-P3605	0	36	0	118.5
HT1256F-P0610	6	0	0	41.7
HT1256F-P1210	12	0	0	67.5
HT1256F-P1810	18	0	0	80.1
HT1256F-P2410	24	0	0	105.6
HT1256F-S09	0	0	9	42.3
HT1256F-S18	0	0	18	67.5
HT1256F-S27	0	0	27	92.7
HT1256F-S36	0	0	36	105.6
HT1256F-P0605-S09	0	6	9	67.5
HT1256F-P0605-S18	0	6	18	80.1
HT1256F-P1205-S09	0	12	9	80.1
HT1256F-P1205-S18	0	12	18	92.7
HT1256F-P1805-S09	0	18	9	92.7
HT1256F-P1805-S18	0	18	18	118.5
HT1256F-P0610-S09	6	0	9	67.5
HT1256F-P0610-S18	6	0	18	92.7
HT1256F-P1210-S09	12	0	9	80.7
HT1256F-P1210-S18	12	0	18	105.6

空心轴滑环系列

HT1256 系列外形图 HT1256 Series Dimensions

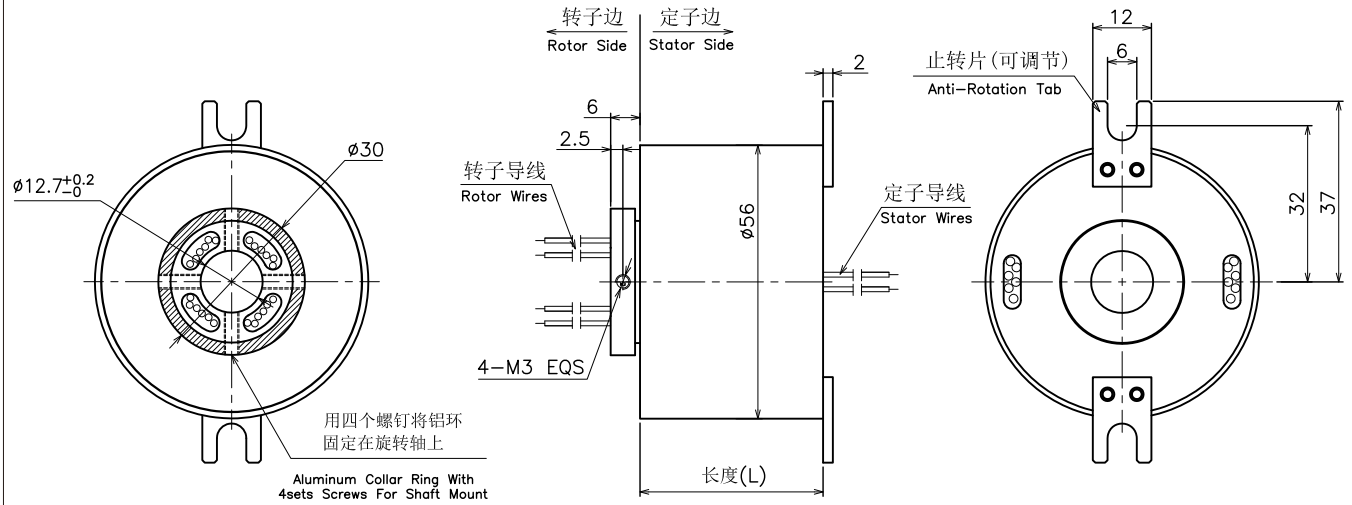

HT1256F 系列外形图 HT1256F Series Dimensions

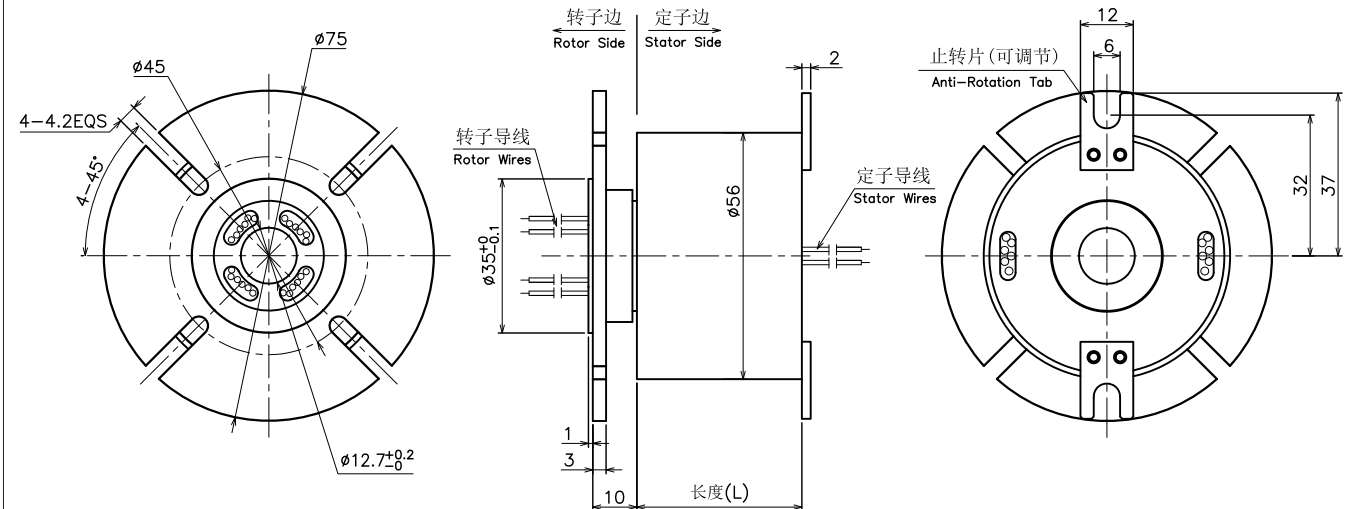

空心轴滑环系列

HT2578系列选型表

HT2578系列 HT2578 Series				
型号 Part NO.	线路数 NO.of Circuits			长度L(mm) Length (mm)
	10A	5A	信号Signal	
HT2578-P0605	0	6	0	47.1
HT2578-P1205	0	12	0	68.7
HT2578-P1805	0	18	0	68.7
HT2578-P2405	0	24	0	90.3
HT2578-P3005	0	30	0	111.9
HT2578-P3605	0	36	0	133.5
HT2578-P0610	6	0	0	47.1
HT2578-P1210	12	0	0	68.7
HT2578-P1810	18	0	0	90.3
HT2578-P2410	24	0	0	111.9
HT2578-P3010	30	0	0	133.5
HT2578-S09	0	0	9	47.1
HT2578-S18	0	0	18	68.7
HT2578-S27	0	0	27	90.3
HT2578-S36	0	0	36	111.9
HT2578-P0605-S09	0	6	9	68.7
HT2578-P0605-S18	0	6	18	90.3
HT2578-P0605-S27	0	6	27	111.9
HT2578-P1205-S09	0	12	9	90.3
HT2578-P1205-S18	0	12	18	111.9
HT2578-P1205-S27	0	12	27	133.5
HT2578-P1805-S09	0	18	9	111.9
HT2578-P1805-S18	0	18	18	133.5
HT2578-P2405-S09	0	24	9	111.9
HT2578-P2405-S18	0	24	18	133.5
HT2578-P3005-S09	0	30	9	133.5
HT2578-P0610-S09	6	0	9	68.7
HT2578-P0610-S18	6	0	18	90.3
HT2578-P0610-S27	6	0	27	111.9
HT2578-P1210-S09	12	0	9	90.3
HT2578-P1210-S18	12	0	18	111.9
HT2578-P1810-S09	18	0	9	111.9
HT2578-P1810-S18	18	0	18	133.5
HT2578-P2410-S09	24	0	9	133.5

空心轴滑环系列

HT2578F系列选型表

HT2578F系列 HT2578F Series				
型号 Part NO.	线路数 NO.of Circuits			长度L(mm) Length (mm)
	10A	5A	信号Signal	
HT2578F-P0605	0	6	0	47.1
HT2578F-P1205	0	12	0	68.7
HT2578F-P1805	0	18	0	68.7
HT2578F-P2405	0	24	0	90.3
HT2578F-P3005	0	30	0	111.9
HT2578F-P3605	0	36	0	133.5
HT2578F-P0610	6	0	0	47.1
HT2578F-P1210	12	0	0	68.7
HT2578F-P1810	18	0	0	90.3
HT2578F-P2410	24	0	0	111.9
HT2578F-P3010	30	0	0	133.5
HT2578F-S09	0	0	9	47.1
HT2578F-S18	0	0	18	68.7
HT2578F-S27	0	0	27	90.3
HT2578F-S36	0	0	36	111.9
HT2578F-P0605-S09	0	6	9	68.7
HT2578F-P0605-S18	0	6	18	90.3
HT2578F-P0605-S27	0	6	27	111.9
HT2578F-P1205-S09	0	12	9	90.3
HT2578F-P1205-S18	0	12	18	111.9
HT2578F-P1205-S27	0	12	27	133.5
HT2578F-P1805-S09	0	18	9	111.9
HT2578F-P1805-S18	0	18	18	133.5
HT2578F-P2405-S09	0	24	9	111.9
HT2578F-P2405-S18	0	24	18	133.5
HT2578F-P3005-S09	0	30	9	133.5
HT2578F-P0610-S09	6	0	9	68.7
HT2578F-P0610-S18	6	0	18	90.3
HT2578F-P0610-S27	6	0	27	111.9
HT2578F-P1210-S09	12	0	9	90.3
HT2578F-P1210-S18	12	0	18	111.9
HT2578F-P1810-S09	18	0	9	111.9
HT2578F-P1810-S18	18	0	18	133.5
HT2578F-P2410-S09	24	0	9	133.5

空心轴滑环系列

HT2578 系列外形图 HT2578 Series Dimensions

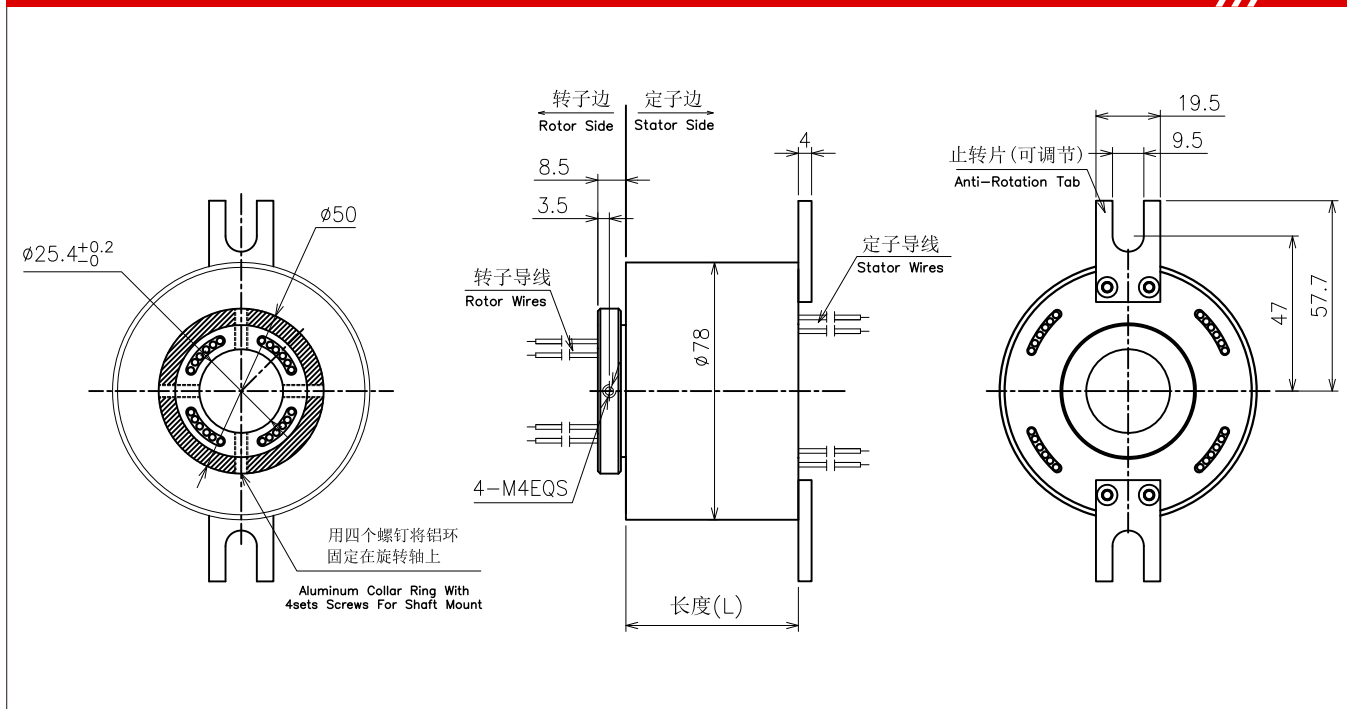

HT2578F 系列外形图 HT2578F Series Dimensions

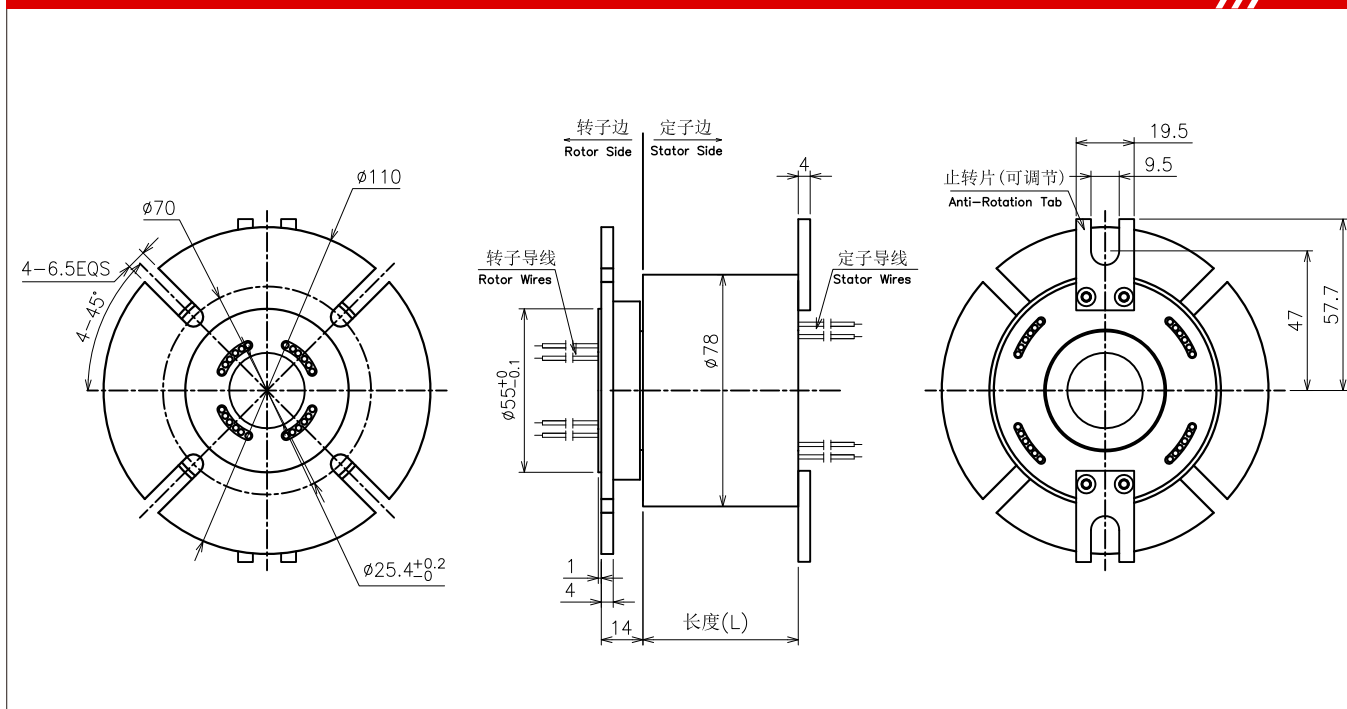

空心轴滑环系列

HT3899系列选型表

HT3899系列 HT3899 Series				
型号 Part NO.	线路数 NO.of Circuits			长度L(mm) Length (mm)
	10A	5A	信号Signal	
HT3899-P0605	0	6	0	47.1
HT3899-P1205	0	12	0	68.7
HT3899-P1805	0	18	0	68.7
HT3899-P2405	0	24	0	90.3
HT3899-P3005	0	30	0	111.9
HT3899-P3605	0	36	0	133.5
HT3899-P0610	6	0	0	47.1
HT3899-P1210	12	0	0	68.7
HT3899-P1810	18	0	0	90.3
HT3899-P2410	24	0	0	111.9
HT3899-P3010	30	0	0	133.5
HT3899-S09	0	0	9	47.1
HT3899-S18	0	0	18	68.7
HT3899-S27	0	0	27	90.3
HT3899-S36	0	0	36	111.9
HT3899-P0605-S09	0	6	9	68.7
HT3899-P0605-S18	0	6	18	90.3
HT3899-P0605-S27	0	6	27	111.9
HT3899-P1205-S09	0	12	9	90.3
HT3899-P1205-S18	0	12	18	111.9
HT3899-P1205-S27	0	12	27	133.5
HT3899-P1805-S09	0	18	9	111.9
HT3899-P1805-S18	0	18	18	133.5
HT3899-P2405-S09	0	24	9	111.9
HT3899-P2405-S18	0	24	18	133.5
HT3899-P3005-S09	0	30	9	133.5
HT3899-P0610-S09	6	0	9	68.7
HT3899-P0610-S18	6	0	18	90.3
HT3899-P0610-S27	6	0	27	111.9
HT3899-P1210-S09	12	0	9	90.3
HT3899-P1210-S18	12	0	18	111.9
HT3899-P1810-S09	18	0	9	111.9
HT3899-P1810-S18	18	0	18	133.5
HT3899-P2410-S09	24	0	9	133.5

空心轴滑环系列

HT3899F系列选型表

HT3899F系列 HT3899F Series				
型号 Part NO.	线路数 NO.of Circuits			长度L(mm) Length (mm)
	10A	5A	信号Signal	
HT3899F-P0605	0	6	0	47.1
HT3899F-P1205	0	12	0	68.7
HT3899F-P1805	0	18	0	68.7
HT3899F-P2405	0	24	0	90.3
HT3899F-P3005	0	30	0	111.9
HT3899F-P3605	0	36	0	133.5
HT3899F-P0610	6	0	0	47.1
HT3899F-P1210	12	0	0	68.7
HT3899F-P1810	18	0	0	90.3
HT3899F-P2410	24	0	0	111.9
HT3899F-P3010	30	0	0	133.5
HT3899F-S09	0	0	9	47.1
HT3899F-S18	0	0	18	68.7
HT3899F-S27	0	0	27	90.3
HT3899F-S36	0	0	36	111.9
HT3899F-P0605-S09	0	6	9	68.7
HT3899F-P0605-S18	0	6	18	90.3
HT3899F-P0605-S27	0	6	27	111.9
HT3899F-P1205-S09	0	12	9	90.3
HT3899F-P1205-S18	0	12	18	111.9
HT3899F-P1205-S27	0	12	27	133.5
HT3899F-P1805-S09	0	18	9	111.9
HT3899F-P1805-S18	0	18	18	133.5
HT3899F-P2405-S09	0	24	9	111.9
HT3899F-P2405-S18	0	24	18	133.5
HT3899F-P3005-S09	0	30	9	133.5
HT3899F-P0610-S09	6	0	9	68.7
HT3899F-P0610-S18	6	0	18	90.3
HT3899F-P0610-S27	6	0	27	111.9
HT3899F-P1210-S09	12	0	9	90.3
HT3899F-P1210-S18	12	0	18	111.9
HT3899F-P1810-S09	18	0	9	111.9
HT3899F-P1810-S18	18	0	18	133.5
HT3899F-P2410-S09	24	0	9	133.5

空心轴滑环系列

HT3899 系列外形图 HT3899 Series Dimensions

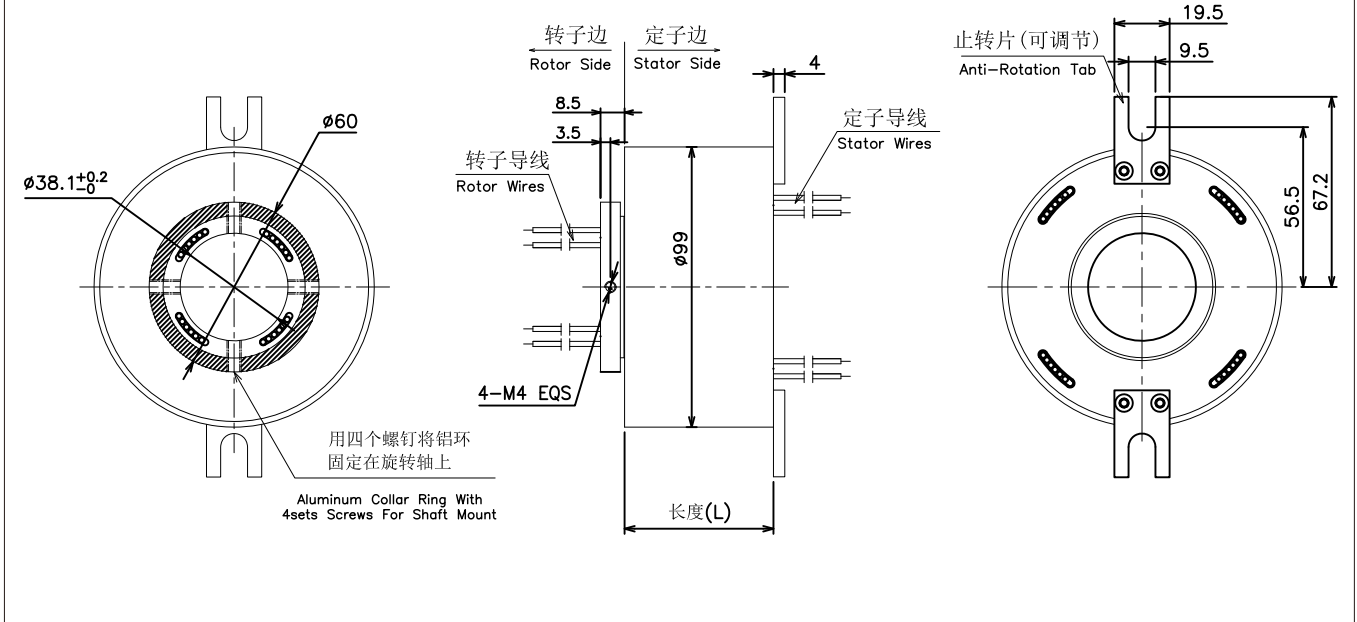

HT3899F 系列外形图 HT3899F Series Dimensions

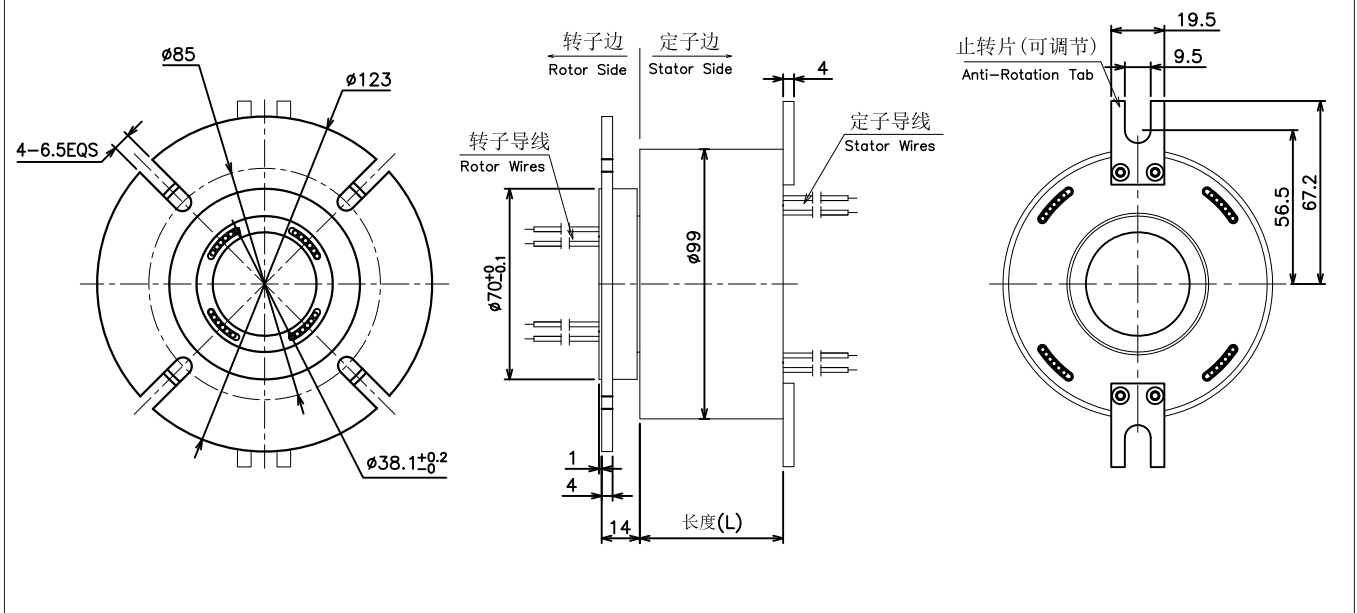

空心轴滑环系列

HT50119系列选型表

HT50119系列 HT50119 Series				
型号 Part NO.	线路数 NO.of Circuits			长度L(mm) Length (mm)
	10A	5A	信号Signal	
HT50119-P0605	0	6	0	52.1
HT50119-P1205	0	12	0	73.7
HT50119-P1805	0	18	0	73.7
HT50119-P2405	0	24	0	95.3
HT50119-P3005	0	30	0	116.9
HT50119-P3605	0	36	0	138.5
HT50119-P0610	6	0	0	52.1
HT50119-P1210	12	0	0	73.7
HT50119-P1810	18	0	0	95.3
HT50119-P2410	24	0	0	116.9
HT50119-P3010	30	0	0	138.5
HT50119-S09	0	0	9	52.1
HT50119-S18	0	0	18	73.7
HT50119-S27	0	0	27	95.3
HT50119-S36	0	0	36	116.9
HT50119-P0605-S09	0	6	9	73.7
HT50119-P0605-S18	0	6	18	95.3
HT50119-P0605-S27	0	6	27	116.9
HT50119-P1205-S09	0	12	9	95.3
HT50119-P1205-S18	0	12	18	116.9
HT50119-P1205-S27	0	12	27	138.5
HT50119-P1805-S09	0	18	9	116.9
HT50119-P1805-S18	0	18	18	138.5
HT50119-P2405-S09	0	24	9	116.9
HT50119-P2405-S18	0	24	18	138.5
HT50119-P3005-S09	0	30	9	138.5
HT50119-P0610-S09	6	0	9	73.7
HT50119-P0610-S18	6	0	18	95.3
HT50119-P0610-S27	6	0	27	116.9
HT50119-P1210-S09	12	0	9	95.3
HT50119-P1210-S18	12	0	18	116.9
HT50119-P1810-S09	18	0	9	116.9
HT50119-P1810-S18	18	0	18	138.5
HT50119-P2410-S09	24	0	9	138.5

空心轴滑环系列

HT50119F系列选型表

HT50119F系列 HT50119F Series				
型号 Part NO.	线路数 NO.of Circuits			长度L(mm) Length (mm)
	10A	5A	信号Signal	
HT50119F-P0605	0	6	0	52.1
HT50119F-P1205	0	12	0	73.7
HT50119F-P1805	0	18	0	73.7
HT50119F-P2405	0	24	0	95.3
HT50119F-P3005	0	30	0	116.9
HT50119F-P3605	0	36	0	138.5
HT50119F-P0610	6	0	0	52.1
HT50119F-P1210	12	0	0	73.7
HT50119F-P1810	18	0	0	95.3
HT50119F-P2410	24	0	0	116.9
HT50119F-P3010	30	0	0	138.5
HT50119F-S09	0	0	9	52.1
HT50119F-S18	0	0	18	73.7
HT50119F-S27	0	0	27	95.3
HT50119F-S36	0	0	36	116.9
HT50119F-P0605-S09	0	6	9	73.7
HT50119F-P0605-S18	0	6	18	95.3
HT50119F-P0605-S27	0	6	27	116.9
HT50119F-P1205-S09	0	12	9	95.3
HT50119F-P1205-S18	0	12	18	116.9
HT50119F-P1205-S27	0	12	27	138.5
HT50119F-P1805-S09	0	18	9	116.9
HT50119F-P1805-S18	0	18	18	138.5
HT50119F-P2405-S09	0	24	9	116.9
HT50119F-P2405-S18	0	24	18	138.5
HT50119F-P3005-S09	0	30	9	138.5
HT50119F-P0610-S09	6	0	9	73.7
HT50119F-P0610-S18	6	0	18	95.3
HT50119F-P0610-S27	6	0	27	116.9
HT50119F-P1210-S09	12	0	9	95.3
HT50119F-P1210-S18	12	0	18	116.9
HT50119F-P1810-S09	18	0	9	116.9
HT50119F-P1810-S18	18	0	18	138.5
HT50119F-P2410-S09	24	0	9	138.5

空心轴滑环系列

HT50119 系列外形图 HT50119 Series Dimensions

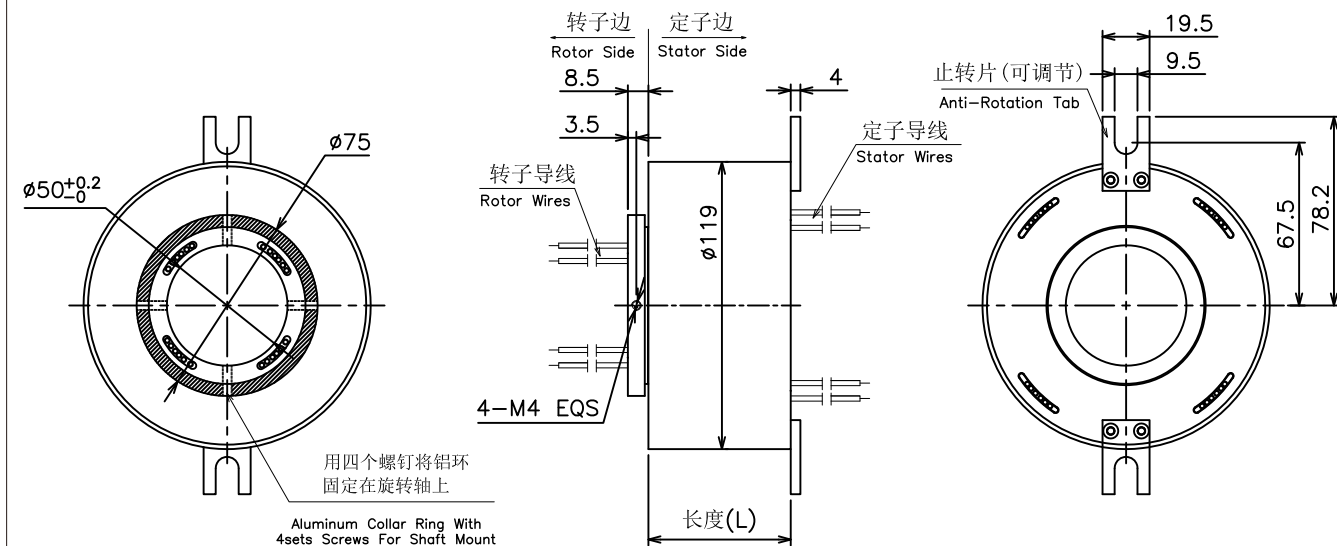

HT50119F 系列外形图 HT50119F Series Dimensions

